

Burford®

Multi-Product Auto-Fill System

MODEL MPAS-100

The Burford® Multi-Product Auto-Fill (MPAS) is uniquely designed to transfer a wide variety of toppings from a bulk storage tank to the hopper located on the Burford® Seeder. The MPAS-100 series utilizes vacuum to gently move topping automatically up to 50 feet. The MPAS-100 also features an automatic filter and tube cleaning system to reduce product changeover times and minimize maintenance requirements.

- Ideal for applications that contain higher amounts of dust
- Gentle on delicate toppings
- Automatic filter cleaning
- Low maintenance
- Flexible anti-static hose for topping transfer, 50ft. max.

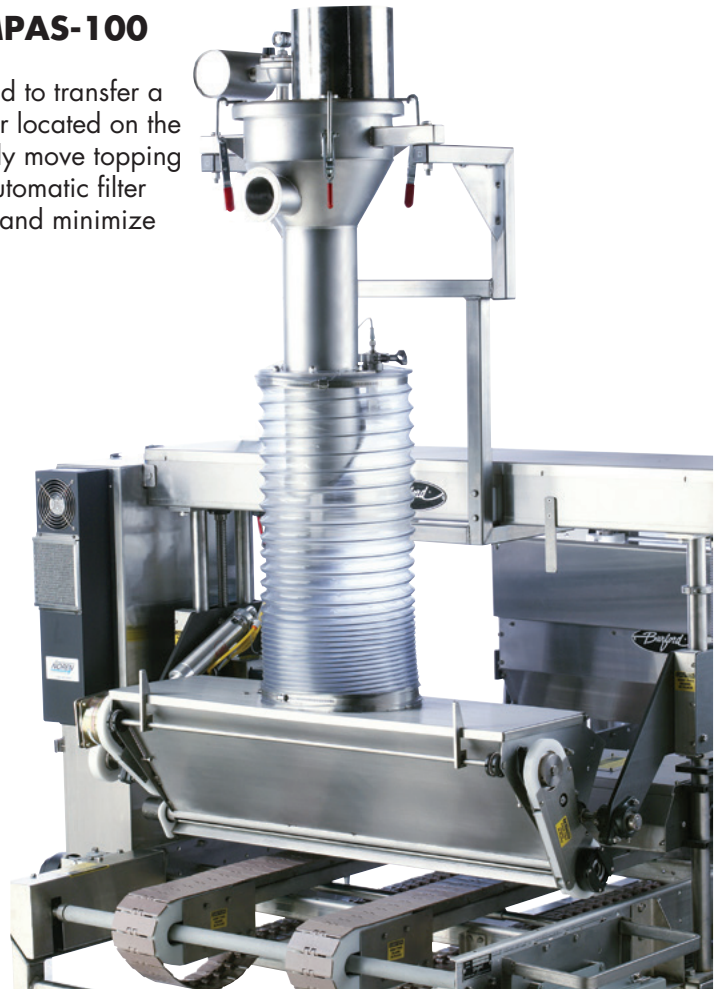

MPAS-100 shown with Burford® seeder and conveyor

Includes MPHS-300 - 300 lbs capacity,
shown with optional tank vibrator kit

PRACTICAL SOLUTIONS THROUGH INNOVATIVE TECHNOLOGIES

Burford®
(bc)

CALL US TODAY 1-877-BURFORD (287-3673)

P.O. Box 748 • Maysville, OK 73057 • 1-405-867-4467 • Fax 1-405-867-4219 • e-mail: sales@burford.com • website: www.burford.com

Copyright © Burford Corp. All rights reserved. Burford Corp is a registered trademark with the US Patent & Trademarks office.

MULTI-PRODUCT AUTO-FILL SYSTEM



Options:

- Tank vibrator kit
- Tank low level alarm
- Stand alone controls
- Floor mount stand

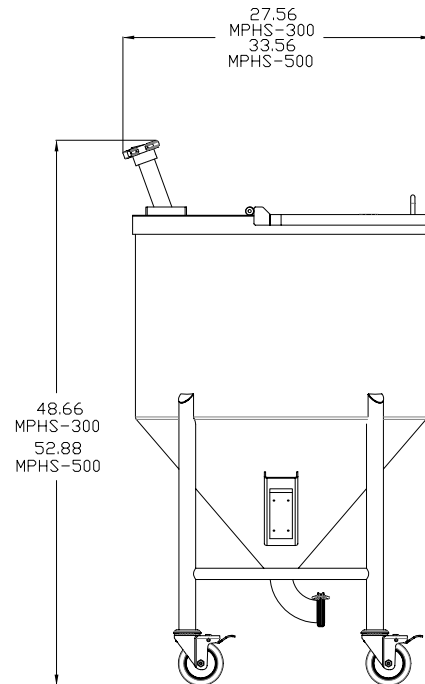
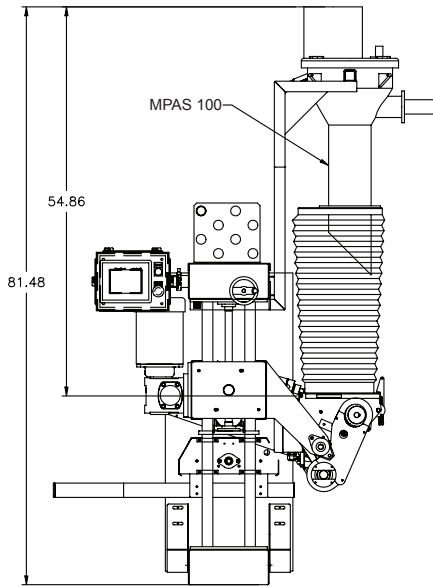
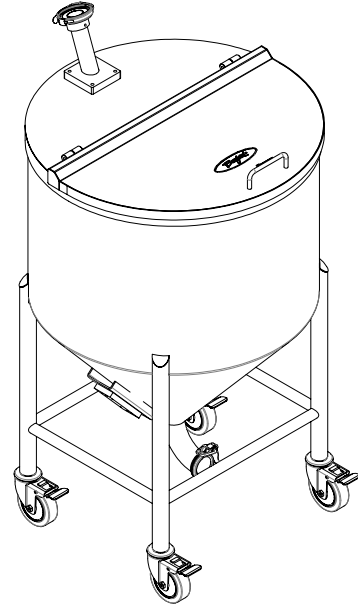
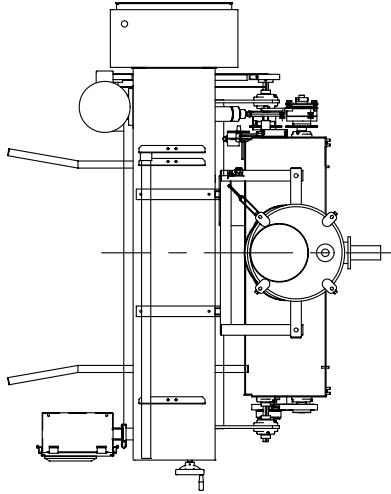

SPECIFICATIONS	
ELECTRICAL:	110 VOLT, 50/60 HZ, 1 PHASE, 10 AMPS
AIR:	80 PSI, @ 1 SCFM (Max)
PRODUCT FLOW:	MAX RATE: SESAME 25lbs/MIN, BRAN & OATS 10lbs/MIN